

VS-TP

FURNACE TEMPERATURE PROBE

The VS - TP furnace temperature probe system is designed for installation in boilers and furnaces to monitor the furnace gas temperature. The thermocouple fixed to the head of the probe moves front and back in the boiler at a speed of 1.75m/min.

The VS - TP temperature probe, offers to monitor the temperature at different levels in a boiler. The thermocouple feedbacks signal to the DCS.



SALIENT FEATURES

- State of the art Design.
- Low cost with additional benefits.
- Low cost maintenance.
- Helps in fast and safe furnace start up.
- Helps in keeping a constant check in gas temperature in the furnace.
- Helps in monitoring the furnace temperature right from lighting off till the furnace goes to load.
- Highly reliable in operation for various modern, heavy duty, utility and industrial boilers.
- The probe moves back and forth across the furnace and is driven by a single 1.1 KW motor.
- The movement of the probe can be controlled using an external control box at location or can be controlled remotely also.
- The temperature probe would send an alarm if the furnace temperature reaches the 1st setting value (TS-1).
- The temperature probe would automatically retract if the furnace temperature reaches the 2nd setting value (TS-2).
- Sensors and limit switches in place to monitor the system and generate an alarm signal incase of danger.
- Probe tube cooling system prevents the tube from burning or bending under high temperature.
- Can be Provided with Time Stamping and Alarm Annunciation systems.
- Furnace temperature Probe Tube is available in 3 different variants Non- cooling, Air cooling and Water cooling.



VS - TP TEMPERATURE PROBE STRUCTURE

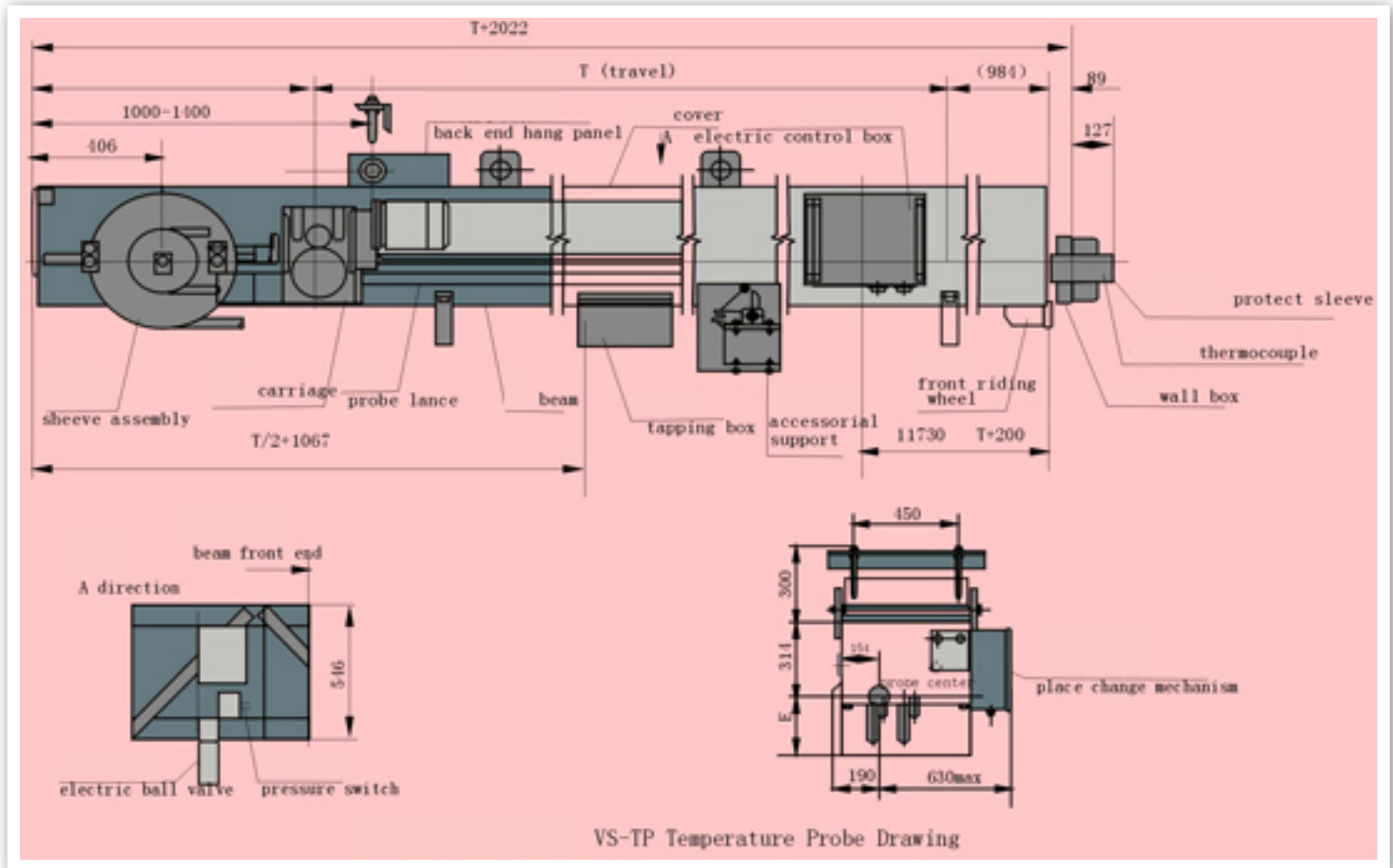

VS - TP TEMPERATURE PROBE ELECTRIC

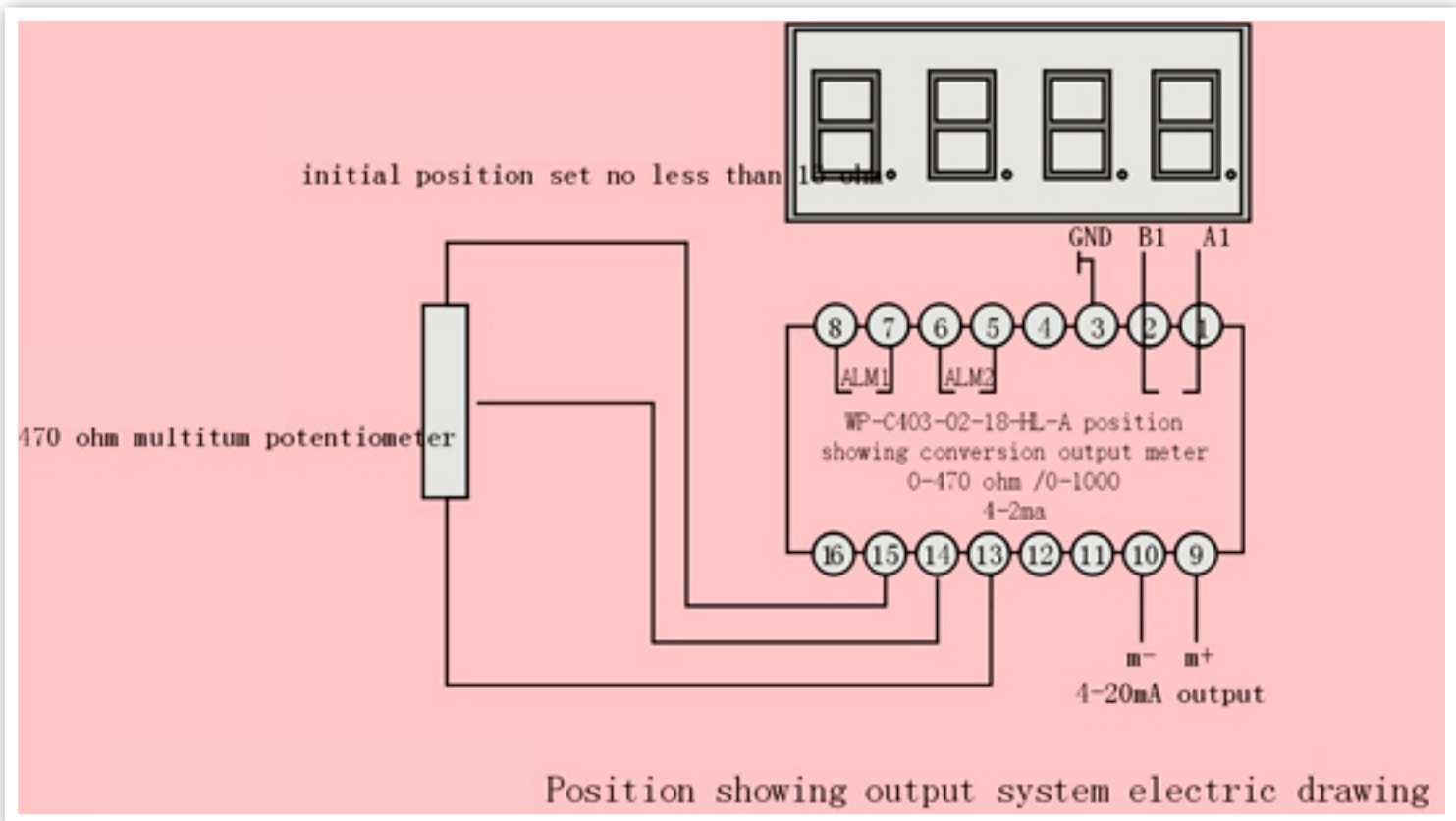

1. Structure Instruction

a) Drive and Support System:

It's made up of beam, carriage, probe tube, cable branch box, pulley yoke and wall box

b) Temperature Measuring and Control System:

It's made up of thermocouple, compensation lead and electric control box

c) Output Meter of Position Display:

It's made up of potentiometer and output meter of position display

d) Probe Tube Cooling System:

It's made up of electric control valve, hose and pressure switch

e) Operation and Display Meters System:

Can be customized as per project requirements.

2. Principle Parameters of VS-TP

Travel	7100mm
Temperature Field	<610 °C
Thermocouple Type	HR-WRNC-2-291
Material of Probe Tube	304
OD of Probe Tube	¢ 89
Speed	~1.75m/min
Output Meter of Position Display	4~20mA
Output Meter of Temperature Display	4~20mA
Motor	Y90S-4 1.1KW 1400rpm 380V 50Hz 3P
Appro. Weight	~250+115*travel in meter

SERTEL ELECTRONICS (PVT.) LIMITED:

"SREYAS BUILDING" 377,
NEHRU NAGAR, 1ST CROSS STREET, P.B.5057,
OLD MAHABALIPURAM ROAD, CHENNAI-600 096.

Tel: 044-23454060

044-23454062

Fax: 044-23454061

E-mail: info@serteltelser.com

sertel@sify.com

SERTEL ELECTRONICS UK LIMITED:

33 LIONEL STREET
BIRMINGHAM, B3 1AB
UNITED KINGDOM

Tel: +44 (0) 121 6616479

+44 (0) 121 6616499

E-mail: enquiryuk@serteltelser.com

Website: www.serteltelser.com